

INSTALLATION INSTRUCTIONS—7450 Series Glass Tube Rotameters

To get the most from the flowmeter you are about to install take time to read the following information before beginning work.

- 1) Carefully inspect the meter for damage that may have occurred during shipping.
- 2) Make sure your pressure, temperature, fluid and other requirements are compatible with the meter.
- 3) Select a suitable location for installation to prevent excess stress on the meter which may result from:
 - a) Misaligned pipe.
 - b) The weight of related plumbing.
 - c) "Water Hammer" which is most likely to occur when flow is suddenly stopped as with quick closing solenoid and operated valves. (If necessary a surge chamber should be installed. This will also be useful in high pressure start-up situations.)
 - d) Thermal expansion of liquid in a stagnated or valve isolated system.
 - e) Instantaneous pressurization which will stress the meter and could result in tube failure.

Note: In closed thermal transfer or cooling systems install the meter in the cool side of the line to minimize meter expansion and contraction and possible related fluid leaks.

- 4) Handle the meter carefully during installation.
 - a) Use an appropriate amount of Teflon tape on external pipe threads before making connections. Do not use paste or stick type thread sealing products.

b) **Extreme caution should be exercised when using PVC solvent cement around Polycarbonate. Solvents can cause Polycarbonate to stress crack.**

- 5) Install the meter vertically with the inlet port at the bottom.
- 6) Meters should be cleaned with a mild soap solution. This will be an effective cleaner of rust stains. Caution must be used so that materials of construction are not damaged by cleaning solutions. Hard water deposits can be removed with a 5% acetic acid solution (vinegar).

CAUTION:

7) Meters are not oxygen cleaned. Use with incompatible fluids will cause O-rings to swell and break tubes. Meters used in gas service should have suitable valves plumbed in at the inlet and outlet of the meter. The valve at the outlet should be used to create back pressure as required to prevent float bounce. The inlet valve should be used for throttling purposes.

8) **Meters with shields must never be operated without shields securely in place. Failure to use safety shields may result in serious injury to personnel and property.**

9) **Meters without case enclosures are designed to operate in gas service at 14.7 psia. Meters in pressure service must be sufficiently shielded using 3/8" polycarbonate to protect personnel and equipment in the event**

PRESSURE/TEMPERATURE

FITTING MATERIAL	MAXIMUMS
Brass	200°F/200 psig
316 Stainless Steel	200°F/200 psig

NOTE

Pressure and temperature limits are based on a study of the engineering data for particular materials used in construction and on the design of individual models. This information is supplemented by destructive testing results. Maximum pressures suggested are at 70° F. Maximum temperatures suggested are at 0 psig, so pressure and temperature maximums are inversely proportional except for stainless case enclosed meters. Pressure and temperature maximums for these meters are simultaneous. Meters with stainless enclosures must **never** be operated without shields securely in place. Meters exposed to difficult environments such as those created by certain chemicals, excessive vibration or other stress inducing factors could fail at or below the suggested maximums. **Never** operate meters above pressure and temperature maximums. Meter failure could result in damage to equipment and serious personal injury. Always use suitable safety gear including OSHA approved eye protection when working around meters in service. We are happy to pass along chemical compatibility information that has been published by the manufacturers of raw materials used in our products; however, this information should not be construed as a recommendation made by King Instrument Company, Inc. for a specific application. Specifications are subject to change without notice.

KING INSTRUMENT COMPANY

12700 Pala Drive, Garden Grove, CA 92841
Phone (714) 891-0008 Fax (714) 891-0023

7450 SERIES

150mm POLE GUIDED FLOWMETER WITH VALVE

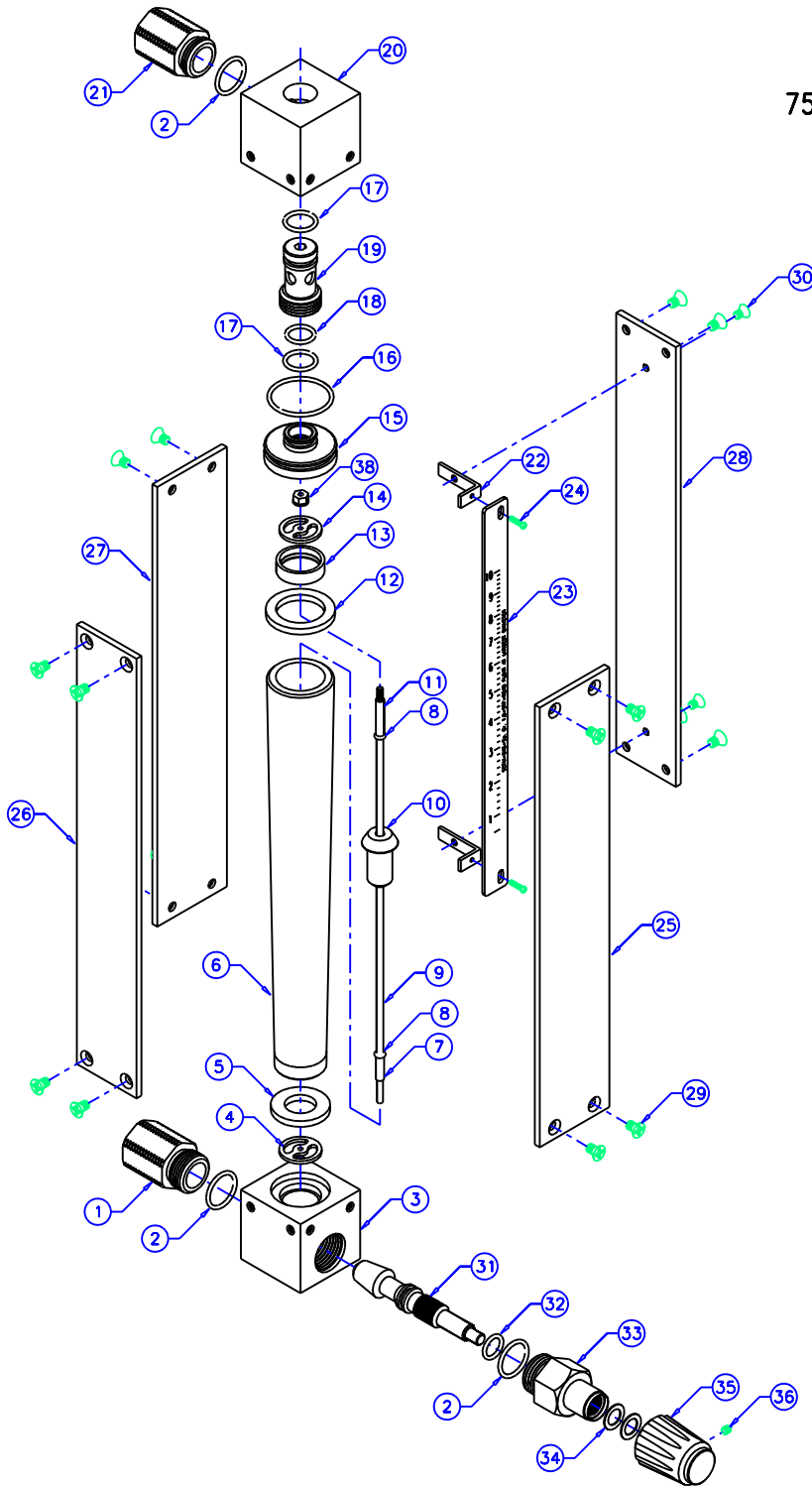

75mm RIB GUIDED FLOWMETER WITHOUT VALVE

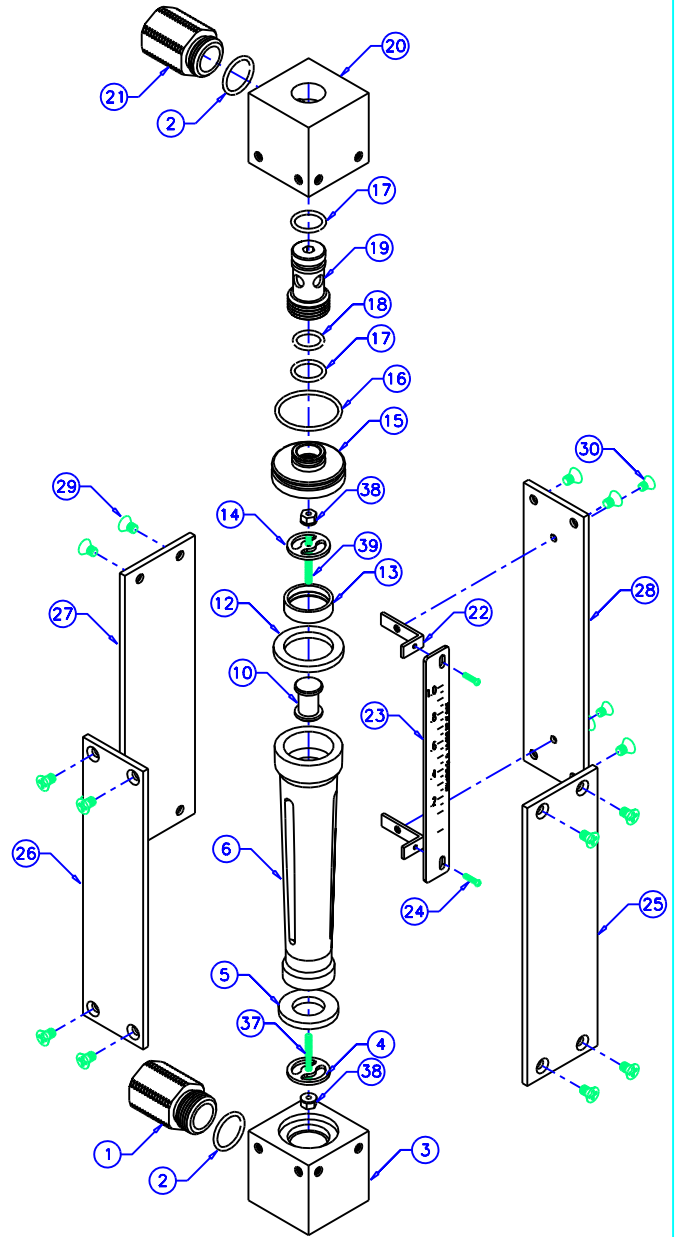

ITEM	PART DESCRIPTION	QTY	ITEM	PART DESCRIPTION	QTY	ITEM	PART DESCRIPTION	QTY
①	INLET FITTING	1	⑭	OUTLET FLOAT STOP	1	⑳	OUTLET BLOCK	1
②	O-RING - 016	3/2	⑮	COMPRESSION SEAT	1	㉑	OUTLET FITTING	1
③	INLET BLOCK	1	⑯	O-RING - 025	1	㉒	SCALE BRACKET	2
④	INLET FLOAT STOP	1	⑰	O-RING - 014	2	㉓	SCALE PLATE	1
⑤	INLET GASKET	1	⑱	O-RING - 013	1	㉔	PHILLIPS HEAD SCREW - 4-40 X 1/4L	2
⑥	METERING TUBE	1	⑲	COMPRESSION FITTING	1	㉕	FRONT SHIELD	1
⑦	INLET GUIDE TUBING	1	㉀	OUTLET BLOCK	1	㉖	STANDARD SIDE PLATE	1
⑧	O-RING - 004	2	㉁	OUTLET FITTING	1	㉗	REAR SHIELD	1
⑨	GUIDE	1	㉂	SCALE BRACKET	2	㉘	SCALE SIDE PLATE	1
⑩	FLOAT	1	㉃	SCALE PLATE	1	㉙	FLAT HEAD PHILLIPS SCREW - 8-32 X 1/4L	16
⑪	OUTLET GUIDE TUBING	1	㉄	PHILLIPS HEAD SCREW - 4-40 X 1/4L	2	㉚	FLAT HEAD PHILLIPS SCREW - 5-40 X 1/4L	2
⑫	OUTLET GASKET	1	㉕	FRONT SHIELD	1	㉛	VALVE STEM	1
⑬	OUTLET FLOAT STOP HOLDER	1	㉖	STANDARD SIDE PLATE	1	㉜	O-RING - 012	1
						㉝	VALVE NUT	1
						㉞	NYLON WASHER	2
						㉟	VALVE KNOB	1
						㊱	SOCKET SET SCREW - 6-32 X 1/4L	1
						㊲	INLET EXTENSION	1
						㊳	HEX NUT (POLE GUIDED, QTY 1)	2
						㊴	OUTLET EXTENSION	1